

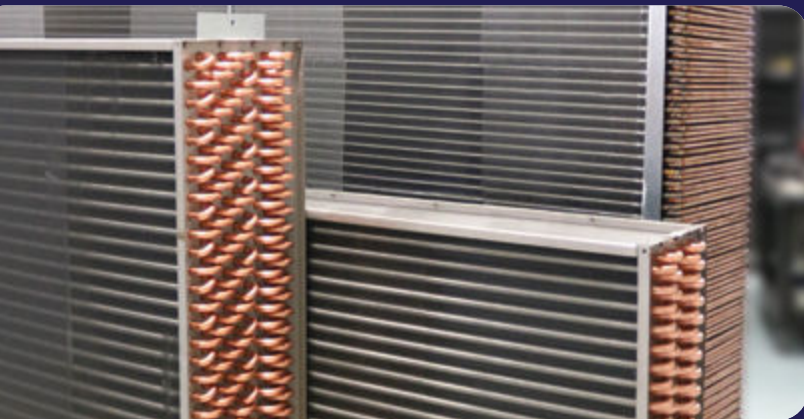

ADVANCED COOLING TECHNOLOGIES

The Thermal Management Experts



# HVAC ENERGY RECOVERY

[solutions@1-act.com](mailto:solutions@1-act.com) | [www.1-act.com](http://www.1-act.com)

# COMPANY OVERVIEW

[CLICK TO VIEW OUR ABOUT US PAGE](#)



At Advanced Cooling Technologies, Inc. (ACT), we specialize in providing innovative thermal management solutions designed to enhance the performance and efficiency of HVAC systems. Since 2003, we have been a trusted leader in heat transfer technology, offering cutting-edge products that optimize energy use, improve indoor air quality, and support sustainable building operations.



Our expertise in advanced energy recovery systems allows us to develop tailored solutions for commercial and industrial HVAC applications. From high-performance heat exchangers to custom thermal control systems, ACT's products are engineered to meet the most demanding environmental and operational requirements.

Our unwavering commitment to Innovation, Teamwork, and Customer Care sets us apart. With state-of-the-art manufacturing facilities, advanced R&D capabilities, and teams of seasoned engineers, we partner with our clients to drive efficiency, sustainability, and performance.

Whether solving today's toughest thermal challenges or innovating for the future, ACT is your trusted partner for thermal management excellence.

## SERVICES WE OFFER

- Design & Analysis
- Thermal Management Consulting
- Prototyping & Low Volume Production
- Product Testing
- Volume Manufacturing
- Spares, Service & Repairs

## QUALITY & CONTINUOUS IMPROVEMENT

ACT is constantly improving our quality assurance processes by adopting new techniques and technologies. Our commitment is to achieve the highest quality standards in the industry, so we can deliver exceptional products and solutions to our customers.



## FACILITY

ACT has over 200,000 square feet of engineering, lab, and manufacturing space, with several unique areas only found in our facilities.

- **Spaceflight Manufacturing:** Highest volume manufacturing in the world for flight-critical constant conductance heat pipes (CCHPs)
- **Facility for Reliably Optimized Server Temperatures (FROST):** Combining R&D and Product Development for next-generation data centers
- **Electrical Engineering Center:** Designing control systems for autonomous operation and energy efficiency across all active product lines
- **Large-Scale Manufacturing:** Delivering industry-leading fielded passive and active cooling systems with unmatched capacity



# HEAT PIPE OPERATION

[CLICK TO VIEW HEAT PIPE OPERATION](#)



Heat pipes in HVAC systems enable efficient thermal transfer through a passive phase-change mechanism, where a working fluid absorbs heat at the evaporator end, vaporizes, and releases thermal energy at the condenser end. Critically positioned with the evaporator below the condenser, gravity assists the condensed liquid's return, creating a continuous cycle that transfers thousands of BTUs with minimal thermal resistance. This design moves heat without external electrical input, making heat pipes a remarkably efficient solution for managing thermal energy in heating and cooling applications.

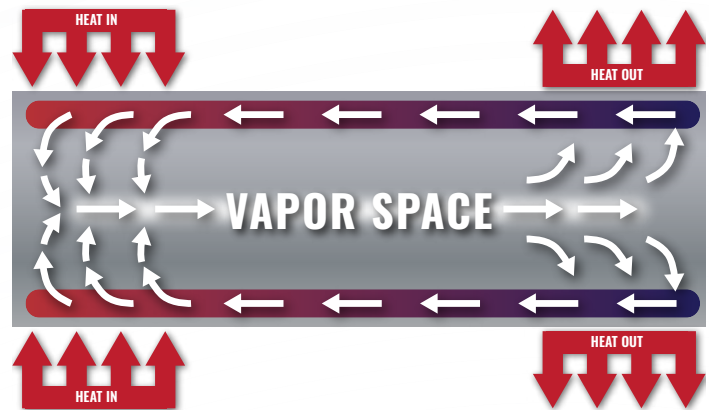

# INSTALLATION SOLUTIONS

ACT provides comprehensive energy recovery installation solutions tailored to your needs.

For Wrap-Around Heat Exchanger (WAHX) systems, our factory installation service allows you to ship your chiller water section directly to our facility, where our expert technicians will precision-fit a heat pipe wrap-around unit to your cooling coil. Using advanced techniques, we ensure complete elimination of air bypass issues that could compromise system performance, maximizing your energy recovery efficiency.



Depending on the size of the air handler, WAHX systems can be partially assembled for easier transportation, then completed on-site with final piping and integration. This modular approach allows for efficient handling of large-scale units and simplifies installation in spaces with limited access.

ACT's Air-to-Air (AAHX) Split Loop Heat Exchangers offer superior installation flexibility compared to traditional Energy Wheels, as they don't require side-by-side positioning for effective energy transfer. The system can operate efficiently with air handlers placed up to 300 feet apart, providing unprecedented layout flexibility for both new construction and retrofits.

Our experienced team manages the entire installation process, from initial delivery to final system connection, ensuring proper assembly and optimal performance.

*Above: Large WAHX systems can be installed in sections.*

*Right: Energy can be easily transferred with Split Loop Air-to-Air Recovery.*

*Far right: A WAHX being installed in an AHU at ACT.*

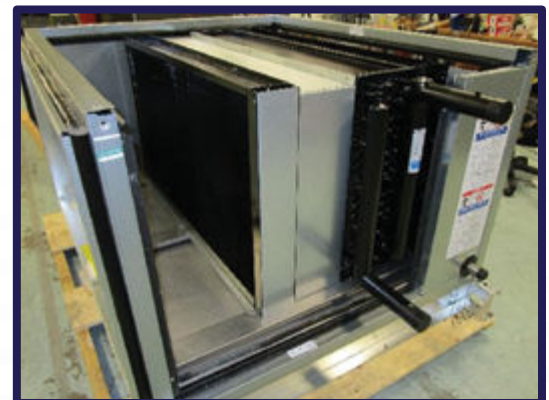

# AIR-TO-AIR HEAT PIPE HEAT EXCHANGER

CLICK TO  
VIEW AAHX



## HOW DOES AN AAHX WORK?

The AAHX is a heat exchanger that uses a series of heat pipes to transfer energy between the outgoing exhaust air stream and the incoming air stream. The cool (summer) or warm (winter) air leaving the building is used to pre-cool or pre-heat the incoming outside air.

## FEATURES & BENEFITS

- Passive system, no moving parts, no maintenance
- No cross-contamination of airstreams
- Any height or length, unit is splittable

## OPTIONS

- Up to 1" diameter copper or aluminum coil tubes
- Multiple fin types and materials
- Controllable
- Corrosion coating (Heresite or E-Coat)
- Pumped systems for vertical installation



ENERGY SAVINGS  
Payback Period  
**2 YEARS**

## CONFIGURATIONS

AAHX units can be oriented to match the AHU or duct work aspect ratio.

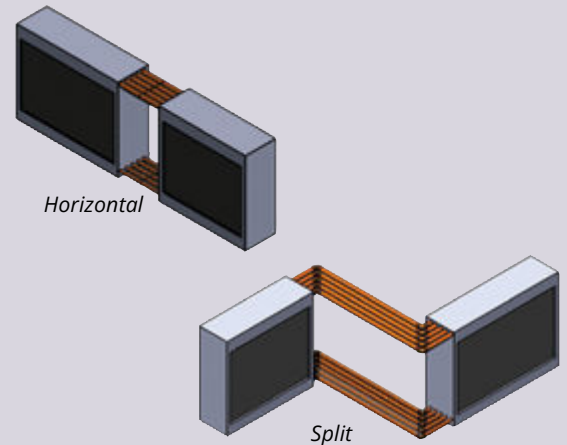
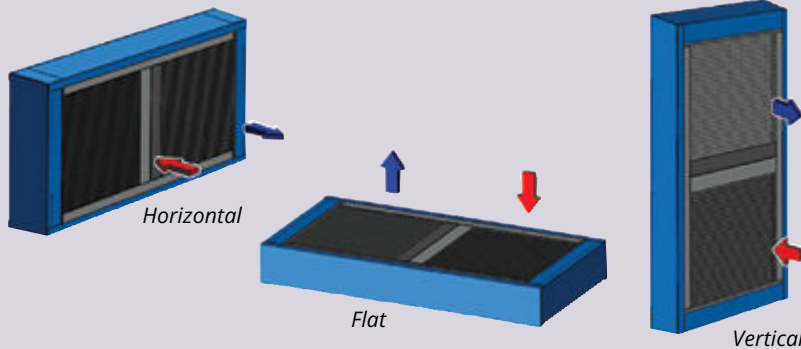

PIPE TO PIPE CONNECTION: EVERY ROW, EVERY PIPE

SPLIT LOOP THERMOSYPHON: 2 PIPES PER ROW

Any coil dimensions • Stackable • Controllable

Any length coil • Stackable • Controllable

## CAPACITY & FROST CONTROL

AAHXs can be equipped with reheat capacity control, which can be used for frost control in extremely cold climates, where the exhaust air is used to defrost any potential ice build up detected by temperature or pressure sensors.



Valves control the reheat in each of the 6 rows, on/off for frost control



## EXAMPLES OF POTENTIAL ENERGY SAVINGS

- Pre-cool and pre-heat with up to 75% effectiveness
- 75° exhaust air pre-cools 95° summer air to 80° with, reducing cooling tonnage load
- 70° exhaust air pre-heats 0° winter air to 52° with, lowering heating expenses
- ACT can provide a comprehensive payback analysis

### SUMMER SEASON - PASSIVE HEAT PIPE OPERATION

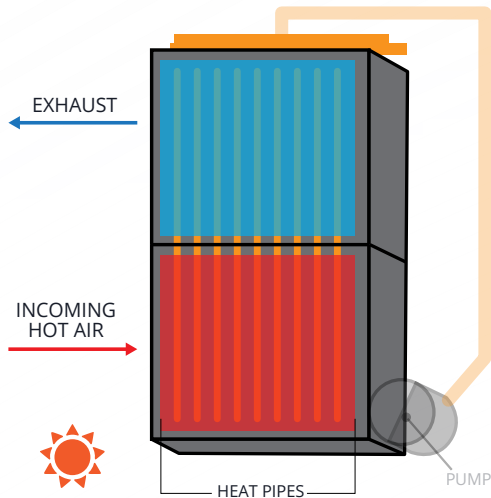

GRAVITY AIDED PASSIVE MODE  
(Precooling incoming hot air with cold exhaust air)

### WINTER SEASON - PUMPED TWO-PHASE OPERATION

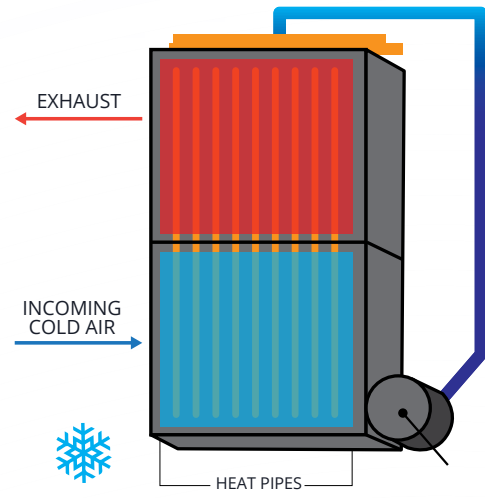

PUMP ASSISTED ACTIVE MODE  
(Reheating incoming cold air with hot exhaust air)

## IDEAL INDUSTRY APPLICATIONS



Hospitals & Healthcare Facilities



Waste & Wastewater Facilities



Vivariums



Toxic VOC Environments



Laboratories & Testing Facilities



Detention Facilities



Universities



High Rises & Skyscrapers



Manufacturing Facilities



Hazardous Area Ventilation

**TRY THE ONLINE SELECTION TOOL**

Our online selection tool was designed by our engineers to help you quickly and easily select the appropriate cooler for your application.



**CLICK TO VIEW SELECTION TOOL**



# AAHX OPTIONS AND ACCESSORIES

## AAHX PUMP-ASSISTED SPLIT-LOOP THERMOSYPHON

In an AAHX Pump-Assisted Split-Loop Thermosyphon Heat Exchanger (SLTS-AAHX), pre-cool and re-heat coils are vertically arranged with separate manifolds. Half-inch diameter tubes allow vapor to rise from the precool coil to the reheat coil, where it condenses and returns as liquid by gravity.

The system uses refrigerant-grade ball valves in the vapor line to control operation. By opening or closing these valves, different sections of the unit can be shut down or activated, providing a simple and flexible cooling method that relies on natural thermosyphon principles.

## FEATURES & BENEFITS

- Compatible with large systems/long distances
- Optional temperature control
- Design flexibility and compact packaging



Above: Half of a large AAHX unit being installed.

Inset: Close-up of the pump-assisted AAHX.

Due to the split-loop thermosyphon design, SLTS-AAHX systems do not need to be side by side and can be up to 300ft apart.

## PUMP-ASSISTED AAHX PERFORMANCE STUDY

Lehigh University installation study

### SPECIFICATIONS USING BETHLEHEM, PA WEATHER DATA

- Natural gas heating: \$0.05/kWh
- Electric cost: \$0.12/k energy recovery unit
- Cooling Coefficient of Performance: 3

### PROJECT HIGHLIGHTS

- Retro-fit to replace an outdated energy wheel
- Payback estimated at 2 years maximum
- Provided a low-maintenance solution

[CLICK TO VIEW LEHIGH CASE STUDY](#)

### TOTAL OPERATING COST SAVINGS OF \$78,215 PER YEAR

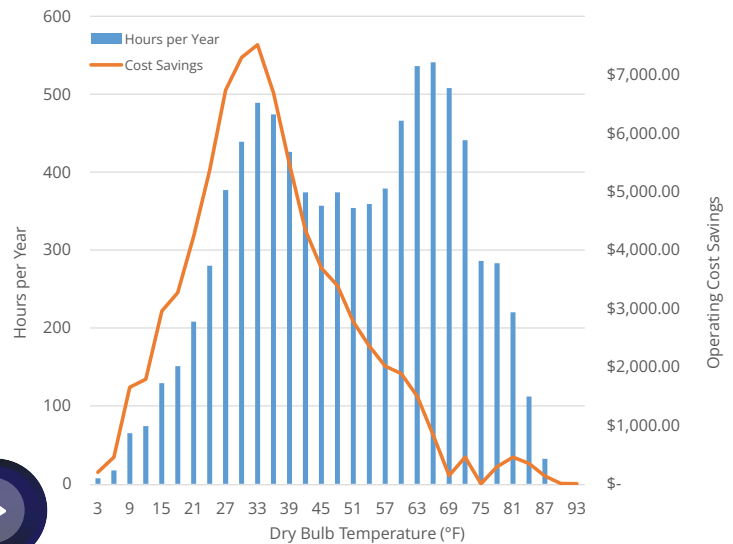

# AAHX AND SLTS-AAHX DIMENSIONS

FRONT VIEW

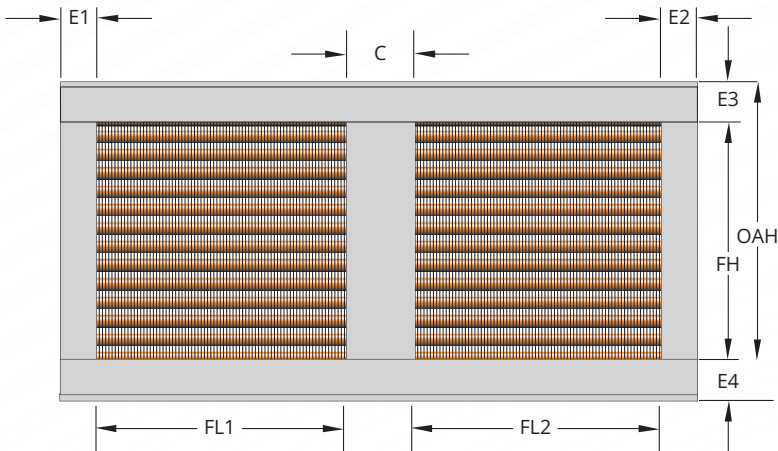

SIDE VIEW

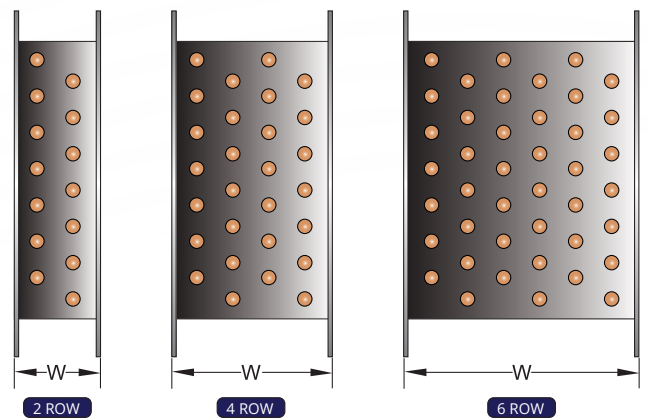

FRONT VIEW DIMENSIONS	
<b>FH: Fin height</b>	Fin Height <b>MUST</b> be in multiples of 1.25"
<b>FL1 &amp; FL2: Fin length</b>	Optional
<b>C: Center divider width</b>	Typically 4.0" / as specified
<b>E1/E2: Side flange</b>	Minimum of 2.0" / as specified
<b>E3/E4: Top/bottom flange</b>	Minimum of 2.0" / as specified

\*Fin height must be the same on the supply and exhaust air streams. Fin lengths can be variable.

SIDE VIEW DIMENSIONS BY # OF ROWS			
ROWS	WIDTH	ROWS	WIDTH
1	2.0"	6	7.5"
2	3.0"	7	8.5"
3	4.0"	8	9.5"
4	5.5"	9	11.0"
5	6.5"	10	12.0"

FRONT VIEW

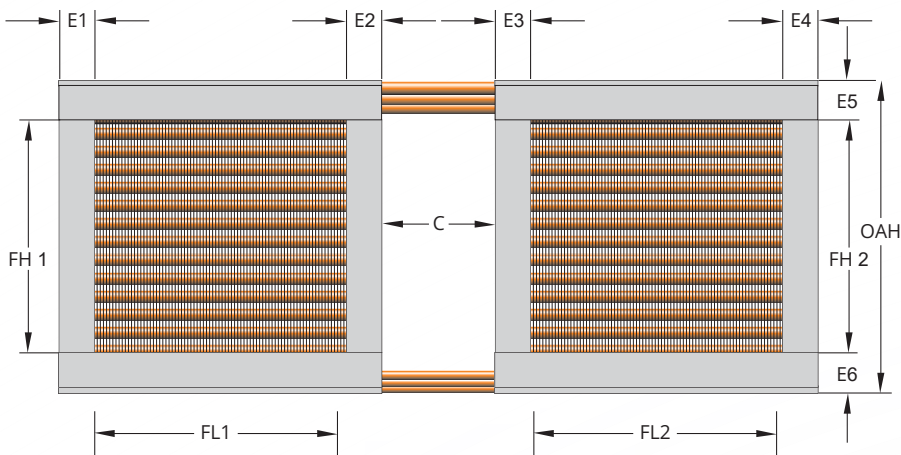

SIDE VIEW

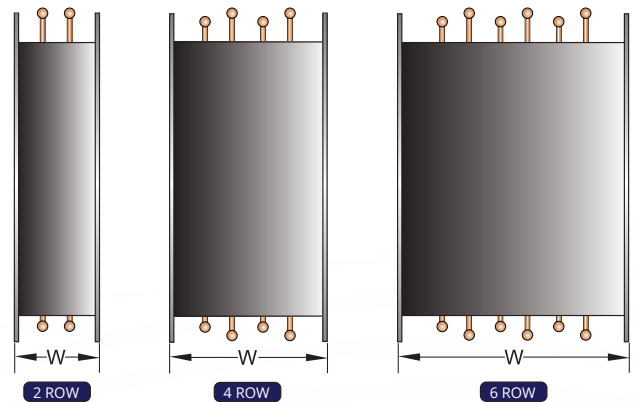

FRONT VIEW DIMENSIONS	
<b>FH1 &amp; 2 Height maximum MUST stack AAHX over 37.5"</b>	Optional
<b>FL1 &amp; FL2: Fin length</b>	Optional, must be in multiples of 1.25"
<b>C: Center divider width</b>	Typically >4.0" up to 30' can be specified
<b>E1-E4: Side flanges</b>	Minimum of 1.5" / as specified
<b>E5: Top flange</b>	Minimum of 4.5" / as specified
<b>E6: Bottom flange</b>	Minimum of 4.0" / as specified

\*Fin height must be the same on the supply and exhaust air streams. Fin lengths can be variable. Split Loop Thermosyphon systems cannot exceed 37.5" in fin height. Units can be stacked to accommodate higher fin height requirements.

SIDE VIEW DIMENSIONS BY # OF ROWS			
ROWS	WIDTH	ROWS	WIDTH
1	3.0"	6	8.0"
2	4.0"	7	9.0"
3	5.0"	8	10.0"
4	6.0"	9	11.0"
5	7.0"	10	12.0"

# WRAP-AROUND HEAT PIPE HEAT EXCHANGER

CLICK TO  
VIEW WAHX



## HOW DOES A WAHX WORK?

The WAHX system features a pre-cool and re-heat coil connected by heat pipes around an existing air handler's cooling coil. It increases dehumidification, saves cooling tonnage, and reduces energy costs by minimizing gas or resistive heating for neutral air temperature discharge.

## FEATURES & BENEFITS

- Free pre-cooling or pre-heating
- Passive system, no moving parts, no maintenance
- Enhanced dehumidification

## OPTIONS

- Up to 1" diameter copper or aluminum coil tubes
- Multiple fin types and materials
- Controllable (active or passive)
- Corrosion coating (Heresite or E-Coat)



ENERGY SAVINGS  
Payback Period  
**2 YEARS**

## CONFIGURATIONS

WAHX units are configured to fit around the existing AHR cooling coil.

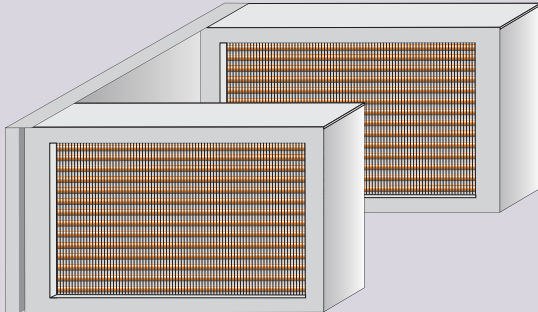

*PIPE TO PIPE CONNECTION: EVERY ROW, EVERY PIPE*

Any coil dimensions • Stackable • Controllable

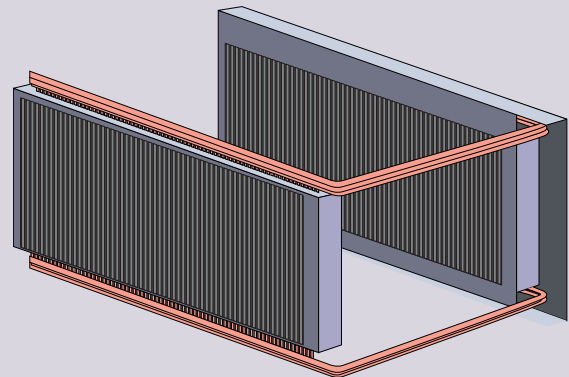

*SPLIT LOOP THERMOSYPHON: 2 PIPES PER ROW*

Any length coil • Stackable • Controllable

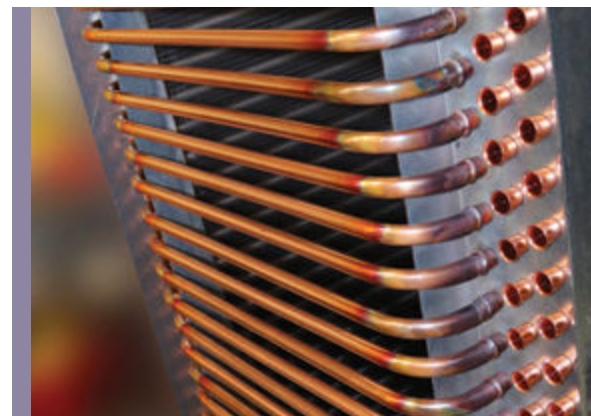
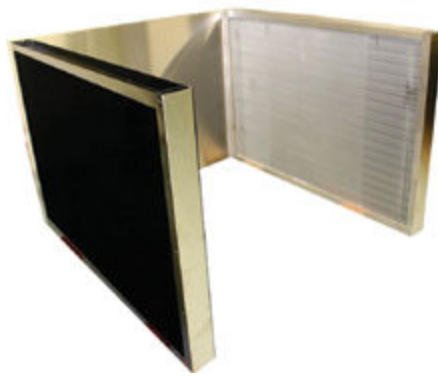
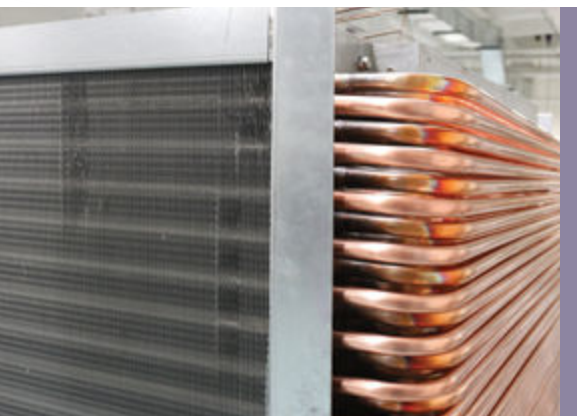

## EXAMPLES OF POTENTIAL ENERGY SAVINGS

- Utilize building exhaust air streams to precool or preheat incoming air
- Air-to-Air energy capture can be side-by-side or split apart up to 30 feet
- ACT Pumped Systems can provide energy recovery of exhaust air streams over 300 feet
- Heat transfer between AHU side-by-side tunnels or split AHU tunnels up to 30 feet



Example of heat transfer capacity control valves



Air-to-Air Split loop energy transfer between 15 foot separated exhaust and supply air AHU's. Precool and preheat incoming air from exhaust AHU.

## IDEAL INDUSTRY APPLICATIONS



Hospitals & Healthcare Facilities



Manufacturing Facilities



Vivariums



Laboratories & Testing Facilities

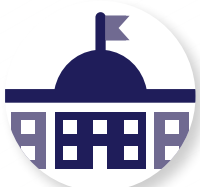

Government & Military Facilities



Universities



Condos, Hotels & Multi-Story Buildings



Natatoriums

## TRY THE ONLINE SELECTION TOOL

Our online selection tool was designed by our engineers to help you quickly and easily select the appropriate cooler for your application.



CLICK TO VIEW SELECTION TOOL



# WAHX OPTIONS AND ACCESSORIES

## WAHX SPLIT-LOOP THERMOSYPHON

In an WAHX Pumped Split Loop Thermosyphon Heat Exchanger, precool and reheat coils are separated and vertically oriented. The coil tubes are arranged with top vapor and bottom liquid manifolds. Vapor naturally rises from the precool coil to the reheat coil, where it condenses and returns by gravity.

Control is achieved through actuated ball valves in the vapor line, which can shut down specific coil circuits or the entire system. This design allows for simple, cost-effective thermal management with flexible control options.

### FEATURES & BENEFITS

- 100% reheat control
- Variable discharge air applications
- Maximize savings while preventing overheating

## ACTIVE THERMAL CONTROL VALVE

In order to capture and transfer even more energy, ACT's thermal control valve options optimize the ability of the WAHX to operate over a wider temperature range and increase the energy savings operation at lower entering air temperatures. ACT thermal control valves permit additional heat pipe rows, resulting in higher capacity WAHX systems with the capability of stopping the heat pipe refrigerant flow in selected rows to maintain a specific discharge temperature, which maximizes energy savings as the outside air temperature fluctuates.

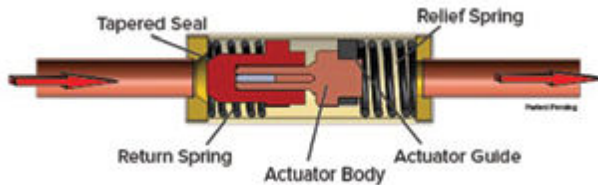

**WAHXs DECREASE  
cooling load by  
35%**



## WAHX PERFORMANCE STUDY

3M Korea - Microchip Manufacturing

### SPECIFICATIONS OF THE PROJECT

- 9 air handling units, ranging in size from 12,220 CFM to 47,250 CFM
- Reduce the activation of the AHU's reheat coils to save on energy costs
- Increase the capacity of the AHUs by requiring less chilled water to maintain stable manufacturing temperature conditions

### PROJECT HIGHLIGHTS

- Total power savings per unit was 119.6 kW, saving over 2.6M kWh of energy per year
- WAHX system reduced humidity, supplying dry, neutral air to the cleanroom environment of the manufacturing space
- Reduced carbon footprint by 1,100 metric tons

TOTAL OPERATING COST SAVINGS OF \$440,000 for 2024

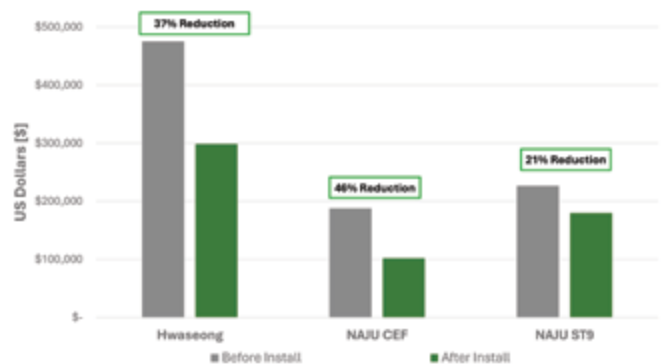

	Annual Savings (Actual + Projected Data)		
	Dollars	MWh	Tons of CO <sub>2</sub>
Facility 1	\$48,321	394.2	170
Facility 2	\$217,147	724.9	312
Facility 3	\$176,439	1,492.9	642
<b>Total</b>	<b>\$441,907</b>	<b>2,612</b>	<b>1,123</b>

# WAHX AND SLTS-WAHX DIMENSIONS

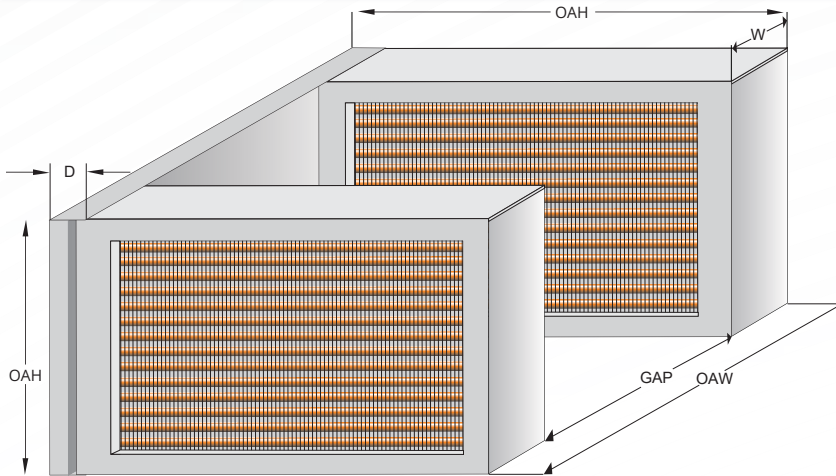

FRONT VIEW DIMENSIONS	
OAH/OAL/OAW: Overall height/length/width	Optional
GAP	Optional
FH: Fin height	Fin height must be in multiples of 1.25"
FL: Fin length	Optional
E1/E2: Side flanges	Minimum of 2.0" or as specified
E3/E4: Top/bottom flange	Minimum of 1.5" or as specified
W: Coil width	See table for minimum / as specified
D: Return tube depth	See table for minimum / as specified

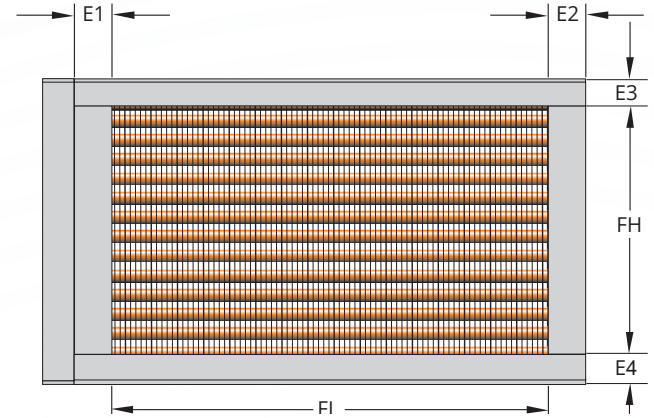

(W) COIL WIDTH BY # OF ROWS			
ROWS	WIDTH	ROWS	WIDTH
1	1.5"	6	7.0"
2	3.0"	7	8.0"
3	4.0"	8	9.25"
4	5.0"	9	10.5"
5	6.0"	10	11.5"

(D) RETURN TUBE DEPTH BY # OF ROWS			
ROWS	WIDTH	ROWS	WIDTH
1	2.0"	6	3.5"
2	2.0"	7	4.25"
3	2.75"	8	4.25"
4	2.75"	9	5.0"
5	3.5"	10	5.0"

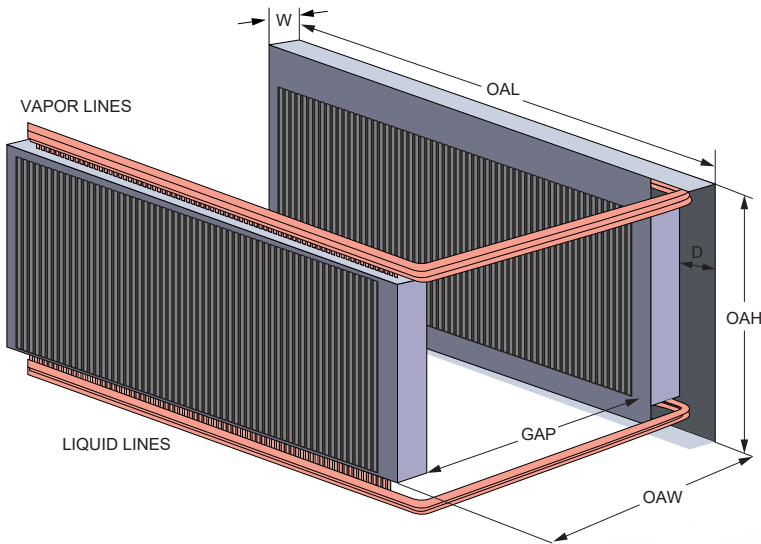

FRONT VIEW DIMENSIONS	
OAH/OAL/OAW: Overall height/length/width	Optional
GAP	Minimum gap is cooling coil dependent, up to 30' can be specified
FH: Fin height	Optional (MAX 37.5")
FL: Fin length	Must be in multiples of 1.25"
E1/E2: Side flanges	Minimum of 1.5" or as specified
E3: Top flange	Minimum of 4.5" or as specified
E4: Bottom flange	Minimum of 4.0"
W: Coil width	See table for minimum / as specified
D: Return tube depth	See table for minimum / as specified

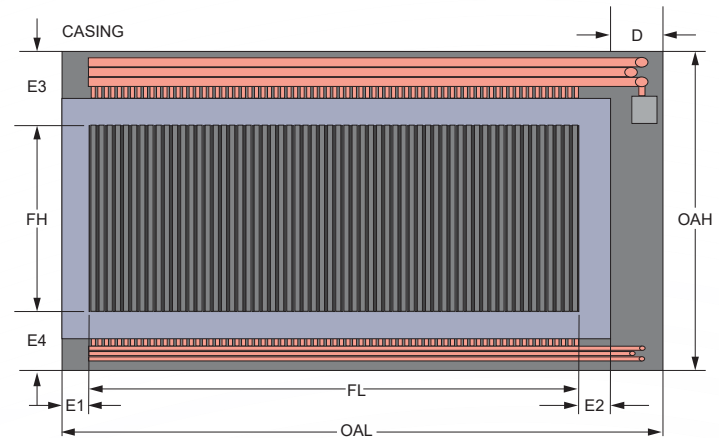

(W) COIL WIDTH BY # OF ROWS					
ROWS	W (W/ CONTROL)	W (NO CONTROL)	ROWS	W (W/ CONTROL)	W (NO CONTROL)
1	4.0"	2.0"	6	13.5"	9.0"
2	6.0"	4.0"	7	15.25"	10.0"
3	7.75"	5.0"	8	17.25"	11.0"
4	9.75"	7.0"	9	20.25"	12.0"
5	11.5"	8.0"	10	22.5"	14.0"

(D) RETURN TUBE DEPTH BY # OF ROWS			
ROWS	WIDTH	ROWS	WIDTH
1	3.0"	6	8.0"
2	4.0"	7	9.0"
3	5.0"	8	10.0"
4	6.0"	9	11.0"
5	7.0"	10	12.0"

\*Split Loop Thermosyphon systems cannot exceed 37.5" in fin height. Units can be stacked to accommodate higher fin height requirements.

# COLLABORATION & PARTNERSHIP

Customer care is at the heart of our approach. We collaborate closely with our corporate partners, offering expert guidance and tailored solutions throughout every stage of product development. Our comprehensive support covers the entire product lifecycle, ensuring your success from initial concept to final production.

## PARTNERING WITH YOU AT ANY POINT IN YOUR PROJECT

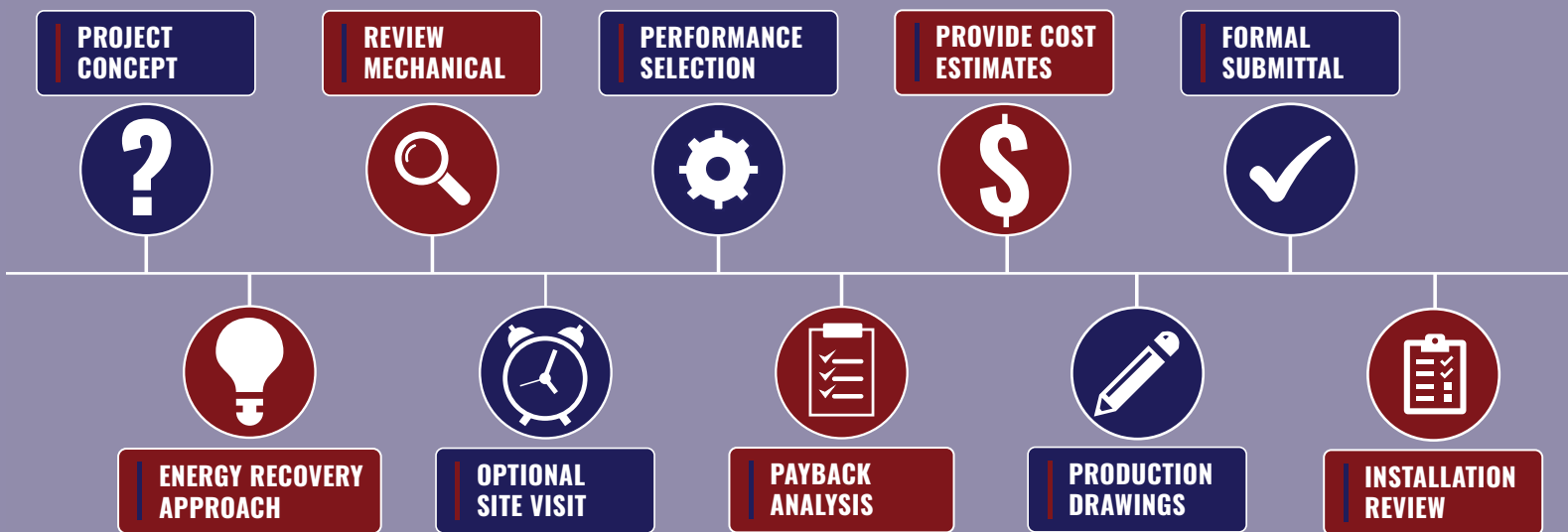

### HEADQUARTERS

1046 New Holland Avenue | Lancaster, PA 17601  
717-295-6061

### YORK OFFICE

3390 Farmtrail Road | York, PA 17406  
717-854-0005



ADVANCED COOLING TECHNOLOGIES

The Thermal Management Experts | [www.1-ACT.com](http://www.1-ACT.com)